

Avtron AV85A THIN-LINE III[™] Encoders

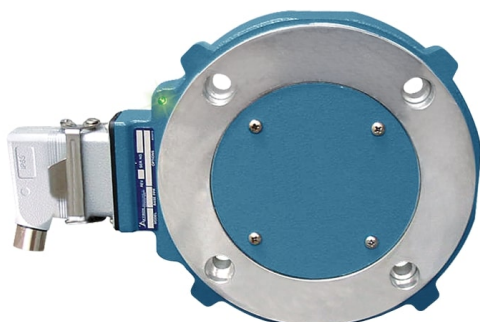

Heavy Mill Duty Magnetic Encoder 8.5" C-Face Mount

Magnetic Durability in a Compact Encoder

Heavy Mill Duty

Simple, Secure Installation

Wide-Gap Technology: No Sensor Scraping or Adjustment

Up to 50000 PPR

No Couplings or Bearings

Sealed Electronics

Self-Diagnostic LED and Alarm Output

Universal 5-24V Operation

3 Year No-Hassle Warranty

All models are protected against all short circuits and wiring errors

AV85A

AV85A THIN-LINE III[™] heavy mill duty modular magnetic encoders fit standard 8.5" C-Face motors and 8.5" flanges commonly used for NEMA brake mounting. Other THIN-LINE III models, ranging from 115mm to 6.75", are available to fit other motor sizes, and AV125 is available for 12.5" NEMA brake applications.

The AV85A is perfect for brake motor applications where the encoder is sandwiched between the motor and brake. With a real-world installation history of over 4,500,000 hour MTBF, you don't have to worry about replacing the encoder!

THIN-LINE III encoders feature simple installation, durable construction, and clear diagnostics to eliminate encoder-related downtime: First, the magnetic sensors are fully potted to withstand dirt and liquids. No glass disks, no optics to clog. There are no moving, wearing parts! The patented Wide-Gap[™] Cam Screw Rotors[™] put an end to sensor damage, are simpler to install, and stay securely mounted to the shaft. The universal 5-24V design drives longer cables and is protected against wiring errors and surges. When you power up an AV85A, you know you installed it right: the green light tells you the digital self-tuning has set your AV85A optimally. If at any time the AV85A cannot produce ideal signals, the LED changes to red and the remote alarm contact activates. However, the encoder keeps working to give you time to schedule service. Any time there are wiring errors, the LED changes to orange. AV85A is the ideal solution to keep your motor and drive system running 24/7/365!

OUTLINE DRAWING

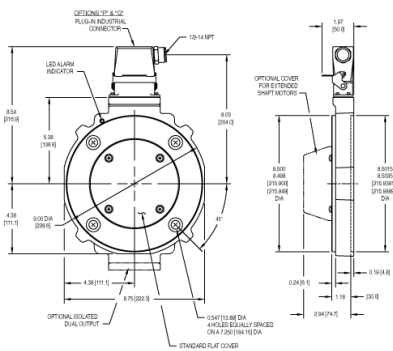

MORE AV85A ADVANTAGES

- Replaces Avtron M85, Northstar/Dynapar™ D8, D850, S8, S85, S850, SL85, ST85; online cross reference guide available
- Shrugs off dirt, oil, and water contamination
- Highly resistant to electrical and magnetic motor and brake noise
- Patented Cam Screw Rotor™ eliminates rotor slipping
- Built-in motor position guide and diagnostic check
- No air gap adjustment required
- Corrosion-resistant coating on all metal surfaces
- Second C-face included for outboard brake/accessory mount
- Sealed thru-shaft option
- Fits shafts 0.500" - 3.188" [10 - 85 mm]
- 4,500,000+ hour MTBF design

MORE AV85A SPECIFICATIONS

Operating Power: Volts: 5 - 24 VDC; Current: 100mA, no load

Output Format: A Quad B with Marker (A./A, B./B, Z./Z)

Second Isolated Output: Optional

Frequency Range:

@5V, @1m cable, 250 kHz Max

@24V, @300m cable, #8 output, 45 kHz Max

Maximum Cable Length: 1000'

PPR: 4 - 50000

Speed: 5400 RPM Max. std., for higher speeds, consult factory

Electronics: Fully Encapsulated, IP67 (see manual for details)

Temperature: -40° to 100°C (150°C rotor)

Vibration: 18 g's

Shock: 1 meter drop test

Chemical: Polyurethane enamel paint protects against salt spray, mild acids, and bases.

Weight: 2 - 3 lbs [0.9 - 1.36 kg]

All dimensions are in inches [millimeters]; Specifications and features are subject to change without notice.

Check out our website for more detailed specifications, drawings, and installation instructions. www.avtronencoders.com



Nidec Industrial Solutions
243 Tuxedo Avenue - Cleveland, Ohio 44131
encoderhelpdesk@nidec-industrial.com
+1 216-642-1230 - www.avtronencoders.com



Features and specifications are subject to change without notice. EU-SMART™, SMARTSafe™, SMARTTach™, THIN-LINE™, WIDE-GAP™, SAFETach™, and BULLSEYE32™ are trademarks of Nidec Industrial Solution. All other trademarks and registered trademarks are the property of their respective owners. Nidec Industrial Solutions' standard warranty applies. All dimensions approximate.

SELECTION GUIDE

MODEL	HOUSING TYPE	ROTOR BORE SIZE	COVER STYLE	LINE DRIVER	LEFT OUTPUT PPR	RIGHT OUTPUT PPR	CONNECTOR OPTIONS	MODIFICATIONS
AV85A	1 - Single Output 2 - Dual, Isolated Outputs	XX - No Rotor CA - 1/2 in. Thru-Shaft Rotor CB - 5/8 in. Thru-Shaft Rotor CC - 7/8 in. Thru-Shaft Rotor CD - 15/16 in. Thru-Shaft Rotor CE - 1 in. Thru-Shaft Rotor CF - 1 1/8 in. Thru-Shaft Rotor CG - 1 1/4 in. Thru-Shaft Rotor CH - 1 3/8 in. Thru-Shaft Rotor CT - 1 1/2 in. Thru-Shaft Rotor CJ - 1 5/8 in. Thru-Shaft Rotor CK - 1 3/4 in. Thru-Shaft Rotor CL - 1 7/8 in. Thru-Shaft Rotor CM - 2 in. Thru-Shaft Rotor CN - 2 1/8 in. Thru-Shaft Rotor CQ - 2 1/4 in. Thru-Shaft Rotor CP - 2 3/8 in. Thru-Shaft Rotor CR - 2 1/2 in. Thru-Shaft Rotor TS - 2 5/8 in. Thru-Shaft Rotor TW - 2 3/4 in. Thru-Shaft Rotor TU - 2 7/8 in. Thru-Shaft Rotor TV - 3 in. Thru-Shaft Rotor T4 - 3 1/8 in. Thru-Shaft Rotor T7 - 3 3/16 in. Thru-Shaft Rotor TZ - 3 1/4 in. Thru-Shaft Rotor D2 - 10mm Thru-Shaft Rotor DA - 11mm Thru-Shaft Rotor D3 - 12mm Thru-Shaft Rotor DB - 14mm Thru-Shaft Rotor DC - 15mm Thru-Shaft Rotor DD - 16mm Thru-Shaft Rotor D4 - 18mm Thru-Shaft Rotor DE - 19mm Thru-Shaft Rotor D7 - 20mm Thru-Shaft Rotor DF - 24mm Thru-Shaft Rotor D5 - 25mm Thru-Shaft Rotor DG - 28mm Thru-Shaft Rotor DH - 30mm Thru-Shaft Rotor DT - 32mm Thru-Shaft Rotor DJ - 36mm Thru-Shaft Rotor DK - 38mm Thru-Shaft Rotor DL - 42mm Thru-Shaft Rotor DM - 45mm Thru-Shaft Rotor DN - 48mm Thru-Shaft Rotor DP - 52mm Thru-Shaft Rotor DR - 55mm Thru-Shaft Rotor DS - 60mm Thru-Shaft Rotor MU - 65mm Thru-Shaft Rotor MV - 70mm Thru-Shaft Rotor MW - 75mm Thru-Shaft Rotor MY - 80mm Thru-Shaft Rotor MZ - 85mm Thru-Shaft Rotor EP - 2 3/8 in. End of Shaft Rotor EN - 2 1/8 in. End of Shaft Rotor	E - Extended (Pie-Pan Style) Cover F - Flat Outboard Cover, Low-Profile T - Outboard Seal Plate for Thru-Shaft with V-Ring Seal G - Extended (Pie-Pan Style) Cover with Gasket for High-Dust Environments X - No Cover Plate	6 - 5-24V In, 5-24V out (7272) recommended for single-ended wiring 8 - 5-24V In/Out (HX) Hi-Power Line Driver, Fully Protected Outputs 9 - 7-24V In, 5v fixed outputs (7272) T - 5-24V In, 5-15V Out	F - 60 PPR G - 100 PPR H - 120 PPR A - 128 PPR L - 240 PPR N - 256 PPR P - 300 PPR E - 360 PPR B - 480 PPR Q - 500 PPR R - 512 PPR S - 600 PPR V - 900 PPR J - 960 PPR W - 1000 PPR Y - 1024 PPR Z - 1200 PPR 3 - 2000 PPR 4 - 2048 PPR 5 - 2500 PPR D - 4096 PPR 8 - 4800 PPR 9 - 5000 PPR 0 - Special PPR	X - No Right Output, Single Output Only F - 60 PPR G - 100 PPR H - 120 PPR A - 128 PPR L - 240 PPR N - 256 PPR P - 300 PPR E - 360 PPR B - 480 PPR Q - 500 PPR R - 512 PPR S - 600 PPR V - 900 PPR J - 960 PPR W - 1000 PPR Y - 1024 PPR Z - 1200 PPR 3 - 2000 PPR 4 - 2048 PPR 5 - 2500 PPR D - 4096 PPR 8 - 4800 PPR 9 - 5000 PPR 0 - Special PPR	A - 10 pin MS style w/o Plug, Avtron/BEI HS35 Pinout B - 10 pin MS style w/o Plug, Dynapar HS35 Pinout C - 10 pin MS style w/ Plug, Avtron/BEI HS35 Pinout D - 10 pin MS style w/ Plug, Danaher HS35 Pinout P - Industrial (EPIC Style) w/mating plug & remote alarm contact G - Ind1 w/Northstar Pinout (EPIC Style connector), w/mating plug, LED diagnostics Q - Ind1 w/Remote Base Mount for Baldor TEFC/IC Motors (EPIC style) w/LED Diagnostics + alarm output Z - Ind1 on 36 inch Cable (side entry) (EPIC Style) w/LED diagnostics + alarm output W - 36 inch Cable w/LED diagnostics + alarm output contact J - Conduit box w/7 pin MS style connector, no mate R - 10 pin Mini-MS style (Bayonet) w/LED diagnostics S - 10 pin Mini-MS style (Bayonet) on 12" cable w/LED diagnostics Y - 10 pin MS style connector on 12 in. cable w/LED diagnostics T - M12 connector on cable (Turck pinout)-requires option 00W U - M12 connector on cable (US pinout)-requires option 00W	000 - None 004 - Add Drain hole (Single Output Only) 005 - Super Magnetic Shielding Added 016 - 6" cable to remote "Q" connector base 017 - Add counterbores to mounting holes for thinnest profile 901 - 0.3m/1' Special Cable Length 902 - 0.6m/2' Special Cable Length 903 - 0.9m/3' Special Cable Length 905 - 1.5m/5' Special Cable Length 910 - 3m/10' Special Cable Length 915 - 4.5m/15' Special Cable Length 920 - 6m/20' Special Cable Length 930 - 9m/30' Special Cable Length 933 - 10m/33' Special Cable Length 00W - Special Connector on 1m/36 inch Cable



Nidec Industrial Solutions
243 Tuxedo Avenue - Cleveland, Ohio 44131
encoderhelpdesk@nidec-industrial.com
+1 216-642-1230 - www.avtronencoders.com



Features and specifications are subject to change without notice. EU-SMART™, SMARTSafe™, SMARTTach™, THIN-LINE™, WIDE-GAP™, SAFETach™, and BULLSEYE32™ are trademarks of Nidec Industrial Solution. All other trademarks and registered trademarks are the property of their respective owners. Nidec Industrial Solutions' standard warranty applies. All dimensions approximate.