

Avtron XR12 SMARTSafe™ Sensor



Severe Duty Magnetostrictive Sensor for XR125 Encoders, Fits Shafts up to 7 7/8" [200mm]

Magnetic Durability in a Compact Encoder

- _____ Fits Shafts up to 7 7/8" [200mm]
- _____ Ideal for Oil and Gas Drilling
- _____ Fully Potted Electronics
- _____ Up to 8192 PPR
- _____ Wide Sensor-Rotor Gap: No Shimming or Scraping
- _____ 3 Year No-Hassle Warranty
- _____ cULus Class I, Div 1 Listed, Groups A,B,C,D
- _____ cULus Class I, Div 2 Listed, Groups A,B,C,D
- _____ ATEX IECEx Rated: Zone 1 & 2, 21 & 22
- _____ cULus Class I Zone Group IIC

XR12

XR12 SMARTSafe™ modular incremental quadrature encoder sensors enable the world's first hazardous duty rotary encoders with removable electronics. They are cULus, ATEX and IECEx certified and offer incredibly reliable no-bearing construction! SMARTSafe sensors can be used in ATEX/IECEx gas and dust and UL gas hazardous environments. Also available: hollow shaft models (XR685), shafted models (XR485), no-bearing modular encoders (XR125, XR850), and modular sensors for smaller bore applications (XR5).

For applications requiring ATEX/IECEx Zone 2 or 22 or cULus Class I, Division 2, Groups A,B,C,D use the XR12 directly in your application, with no barrier, isolator or cable gland required.

For applications requiring UL Division 1, ATEX/IECEx Zone 1 or 21 protection use the XRB3 isolator in your control cabinet which permits the use of intrinsically safe wiring instead of explosion-proof conduit or glands. The XR56 can also be used in UL Class I Div 1 & Zone 0 applications using the XRB3 Isolator.

Unlike the competition, Avtron SMARTSafe encoder systems are protected against short circuits, power-to-output wiring, and output-to-ground faults.

Instead of mounting a tiny optical encoder with weak bearings on a wobbling stub shaft, mount XR12 directly on your machine and install the rotor on your main application or motor shaft. Vibration, shock, liquids, dust and dirt won't harm SMARTSafe™ XR12 encoders! Paint booths, draw works, coil tubing rigs...XR12 can keep them all working 24/7/365.

Eliminate the biggest cause of industrial encoder failure--eliminate the bearings with XR12 hazardous duty encoder sensors!

OUTLINE DRAWING

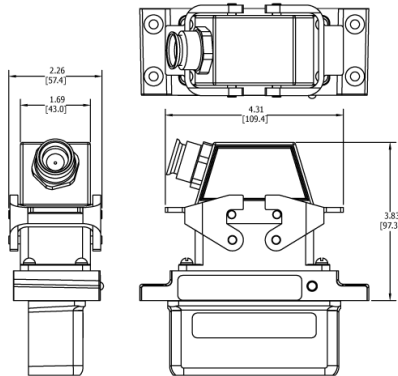

MORE XR12 ADVANTAGES

- Sensor PPR can be factory reprogrammed
- Full protection against short circuits, reverse voltage, phase-to-phase shorts
- Shrugs off dirt, oil, and water contamination
- No glass disks to break or optics to fail
- Sensor for XR125 encoder
- Direct machine-mount capability
- Self-Diagnostic LED and Alarm Output

MORE XR12 SPECIFICATIONS

Operating Power: (add cable drive current as req'd)

Division 1, Zone 1 (XRB3): 12-24VDC in/out, 150 mA

Division 2, Zone 2: 5-24VDC in/out, 150 mA

Output Format: A Quad B with marker (A,/A, B,/B, Z,/Z)

Frequency Range: 0 to 165 kHz

PPR: 8-8192

Speed: 6000 RPM Max. (contact factory for higher speeds)

Maximum Cable Length:

Division 1, Zone 1: Encoder 500' Isolator 1000'

Division 2, Zone 2 (5 to 12 VDC in): 500'

Division 2, Zone 2 (15 to 24 VDC in): 250'

Rotor Positioning: +/-0.100" [+/-2.54mm] movement/misalignment

Sensor-Rotor Gap: 0.045", +0.015/-0.040" [1.14mm+0.38/-1.0]

Temperature: -40°C to 80°C (Storage -40°C to 100°C)

Environmental: Electronics-IP67 (see manual for details)

Vibration: 5-2000Hz, 18G; 100G Shock

Weight: 2.2 lbs. [1kg]

Certifications:

ATEX/IECEX Zone 1 & Zone 21 Group IIC

cULus Class I, Division 1 and Zone 0 Group A,B,C,D*

ATEX/IECEX Zone 2 & 22 Group IIC

cULus Class I, Division 2 Group A,B,C,D

***See installation drawings for Warnings and Limitations**

Check out our website for more detailed specifications, drawings, and installation instructions. www.avtronencoders.com



Nidec Industrial Solutions
243 Tuxedo Avenue - Cleveland, Ohio 44131
encoderhelpdesk@nidec-industrial.com
+1 216-642-1230 - www.avtronencoders.com



Features and specifications are subject to change without notice. EU-SMART™, SMARTSafe™, SMARTTach™, THIN-LINE™, WIDE-GAP™, SAFETach™, and BULLSEYE32™ are trademarks of Nidec Industrial Solution. All other trademarks and registered trademarks are the property of their respective owners. Nidec Industrial Solutions' standard warranty applies. All dimensions approximate.

SELECTION GUIDE

MODEL	LINE DRIVER	PPR	CONNECTOR OPTIONS	MODIFICATIONS
XR12-	H - Level 1 Protection (ATEX/IECEX Zone 1 & 21), 5-7v in, 5v out (NOTE Requires XRB3 Isolator) 7 - Level 2 Protection, (ATEX/IECEX Zone 2 & 22) 5-24v, 5-24V out F - Level 1 Protection, (UL Class I, Div 1, UL/cUL Class I, Zone 0 Listed) 5-7v, 5V out (NOTE Requires XRB3 Isolator) G - Level 2 Protection, (UL Class I, Div 2 Listed) 5-24v, 5-24V out R - US CLASS I, DIV 2, ZONE 2, RECOGNIZED, 5-24v in, 5-24v out	X - No Left Output F - 60 PPR G - 100 PPR H - 120 PPR A - 128 PPR L - 240 PPR N - 256 PPR P - 300 PPR E - 360 PPR B - 480 PPR Q - 500 PPR R - 512 PPR S - 600 PPR V - 900 PPR J - 960 PPR W - 1000 PPR Y - 1024 PPR Z - 1200 PPR 6 - 1800 PPR 3 - 2000 PPR 4 - 2048 PPR 5 - 2500 PPR D - 4096 PPR 8 - 4800 PPR 9 - 5000 PPR 0 - Special PPR	A - 10 pin MS style w/o Mating Plug B - 10 pin MS style w/Plug J - 7 pin MS style w/Plug (A, B, Z) (Standard Phasing) K - 7 pin MS style w/Plug (A, A', B, B') (Standard Phasing) G - Industrial EPIC Style w/LED alarm P - Industrial EPIC Style w/LED and remote alarm contact (level 2 protection only) R - Baldor Mini MS style w/Plug W - 3' Sealed Cable w/Color Coded Leads 2 - "Tall" conduit box, 3/4" NPT threads (ATEX/IECEX/UL/cUL rating) 4 - Std conduit box, 1/2" NPT threads (ATEX/IECEX/UL/cUL rating) 5 - Std conduit box, 3/4" NPT threads (ATEX/IECEX/UL/cUL rating) 6 - Std conduit box, 1" NPT threads (ATEX/IECEX/UL/cUL rating) 7 - Std conduit box, 25mm threads (ATEX/IECEX/UL/cUL rating)	000 - No Special Options 004 - Super Magnetic Shielded Sensor(s) 405 - 16 PPR (Special) Left Output 406 - 6000 PPR (Special) Left Output 407 - 2800 PPR (Special) Left Output 408 - 1400 (Special) Left Output PPR 901 - Special 1/0.3m cable length built into sensor 902 - Special 2/0.6m cable length built into sensor 903 - Special 3/0.9m cable length built into sensor 905 - Special 5/1.5m cable length built into sensor 910 - Special 10/3m cable length built into sensor 915 - Special 15/4.5m cable length built into sensor 920 - Special 20/6m cable length built into sensor 925 - Special 25/7.5m cable length built into sensor 930 - Special 30/9m cable length built into sensor 933 - Special 33/10m cable length built into sensor



Nidec Industrial Solutions
 243 Tuxedo Avenue - Cleveland, Ohio 44131
 encoderhelpdesk@nidec-industrial.com
 +1 216-642-1230 - www.avtronencoders.com



Features and specifications are subject to change without notice. EU-SMART™, SMARTSafe™, SMARTTach™, THIN-LINE™, WIDE-GAP™, SAFETach™, and BULLSEYE32™ are trademarks of Nidec Industrial Solution. All other trademarks and registered trademarks are the property of their respective owners. Nidec Industrial Solutions' standard warranty applies. All dimensions approximate.